



Solicitation Cover Page

1. **Solicitation #: 1681**
2. **Solicitation Issue Date: 7/3/24**
3. **Brief Description of Requirement:**

Kerr House Sump Replacement

4. **Response Due Date: 7/31/24**

Time: 5:00 PM CT

5. **Contracting Officer:**
Name: Stephanie Waits
Phone: 918-960-2221
Cell: 918-530-5672
Email: stephanie.waits@grda.com

We deliver affordable, reliable ELECTRICITY, with a focus on EFFICIENCY and a commitment to ENVIRONMENTAL STEWARDSHIP.

We are dedicated to ECONOMIC DEVELOPMENT, providing resources and supporting economic growth.

Our EMPLOYEES are our greatest asset in meeting our mission to be an Oklahoma Agency of Excellence.

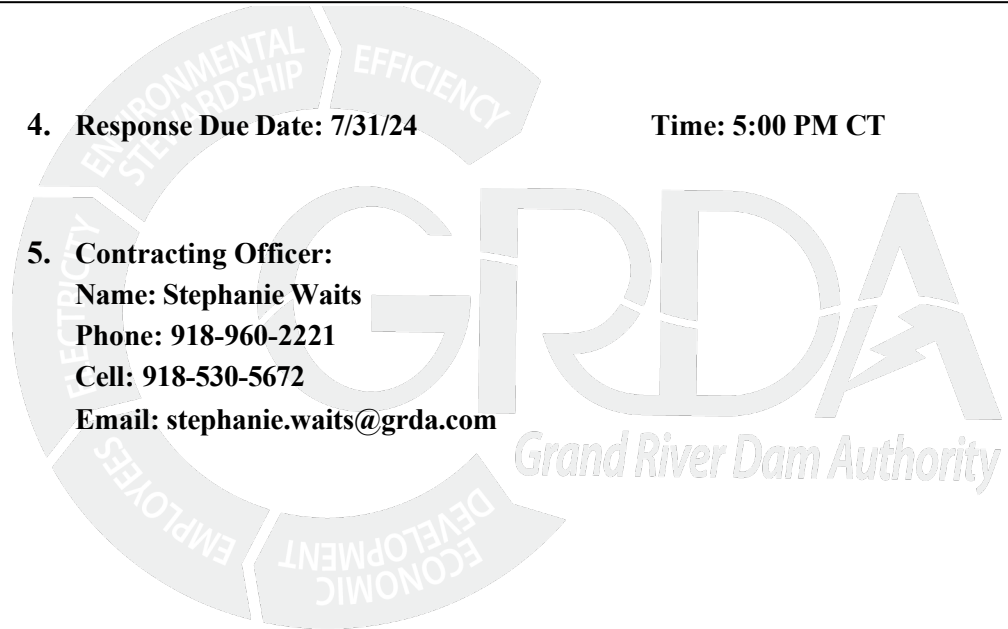



This is a standard bid process; Please submit your bid via email to stephanie.waits@grda.com by **July 31, 2024, at 5:00 PM CST**. All questions must be submitted in writing via email to stephanie.waits@grda.com by July 26, 2024, at 5:00 PM CST.

A completed non-collusion certificate is required and must be submitted with your bid if pricing is over \$5,000.00.

This RFQ form must be signed by an authorized representative of your company in the space provided in the lower right-hand corner of the form.

EVALUATION

The award to the successful bidder will be based on the lowest and best received that meets the specifications listed below and the requirements herein.

The brand names, model(s), part number(s) provided herein are for comparable quality and identification purposes only and equivalent bids may be submitted.

GRDA will take into consideration past performance and ability to meet delivery deadlines (lead time) in the evaluation.

Preference may be given to vendors that accept EPay as method of payment if analysis estimates that such appears to result in a lower cost to GRDA. Additional payment terms may also be taken into consideration in the analysis process.

******* Please read the General Bidding Instructions attached to this RFQ for further instructions. *******

We deliver affordable, reliable **ELECTRICITY**, with a focus on **EFFICIENCY** and a commitment to **ENVIRONMENTAL STEWARDSHIP**.

We are dedicated to **ECONOMIC DEVELOPMENT**, providing resources and supporting economic growth.

Our **EMPLOYEES** are our greatest asset in meeting our mission to be an Oklahoma Agency of Excellence.





****GRDA payment options are EPay (Preferred payment method) or ACH****
Only one form is required to be completed and returned.

GRDA Visa Payment (EPay Program)

NOTE: This is not a credit card payment at time of sale (POS transaction). It is an electronic VISA payment after an invoice has been submitted and processed for payment. Payment terms on VISA payments are in accordance with those agreed upon on the solicitation and the resulting PO/Contract.

When a vendor elects to accept payment by EPay, the vendor will be assigned a 16-digit ghost account number (no physical plastic) which remains at a zero credit limit until an invoice is received from the vendor and processed by GRDA Accounts Payable. Once an invoice from a vendor has been processed for payment the vendor will receive a secure remittance advice via email providing the invoice information and full card account information authorizing the vendor to run the card and post the transaction at which time the account credit limit will return to zero until the next payment.

To learn more about the benefits of the Visa payment program, and to obtain answers to FAQ, click or copy and paste the following URL into your browser:

www.bankofamerica.com/epayablesvendors.

Will accept payment by Visa: Yes No (check one)

Visa acceptance signature: _____

Designated Accounts Receivable Contact for Visa remittance advices:

Name: _____

Phone: _____

Email: _____

If a vendor elects to not accept EPay as the payment method, additional terms which provide discounts for earlier payment may be evaluated when making an award. Any such additional terms shall be for discounts for payment to be made no less than ten (10) days and may increase in five (5) day increments up to thirty (30) days. Discounts offered must be in half or whole percent increments. The date from which the discount time is calculated shall be the date of a valid invoice. An invoice is considered valid if it is sent to the proper recipient, the invoiced goods or services have been received, and the invoice includes sufficient detail as identified in the solicitation.

We deliver affordable, reliable ELECTRICITY, with a focus on EFFICIENCY and a commitment to ENVIRONMENTAL STEWARDSHIP.

We are dedicated to ECONOMIC DEVELOPMENT, providing resources and supporting economic growth.

Our EMPLOYEES are our greatest asset in meeting our mission to be an Oklahoma Agency of Excellence.





GRDA Request for ACH Transaction and Authorization Form

This form does not need to be filled out if you accept EPay as the form of payment. If this form has already been provided to GRDA and you are currently being paid by ACH you do not have to fill the form out again. This form has previously been provided to GRDA. YES: _____

Thank you for providing the following information as GRDA moves toward a more efficient method of ACH as the payment method to our vendors. Please add the ACH routing and account number to future invoices if possible.

Vendor Information

Name: _____

Address: _____

City: _____ State: _____ Zip Code: _____

Email: _____

Phone: _____

Send EFT Email Remittance Advice Yes _____ No _____

If yes, please include email address: _____

ACH Delivery:

Bank Routing Number: _____

Account Number: _____

Bank Name: _____

Bank Address: _____

City: _____ State: _____ Zip Code: _____

Beneficiary Name: _____

Vendor verification signature: _____

Thank you for your business!

Sincerely,

Accounts Payable Department,
Accounts.payable@grda.com

We deliver affordable, reliable ELECTRICITY, with a focus on EFFICIENCY and a commitment to ENVIRONMENTAL STEWARDSHIP.

We are dedicated to ECONOMIC DEVELOPMENT, providing resources and supporting economic growth.

Our EMPLOYEES are our greatest asset in meeting our mission to be an Oklahoma Agency of Excellence.



Electric Motor Driven

Submersible Pump

Model S6D1-E30

Size 6"



PUMP SPECIFICATIONS

- Diffuser:** G-R Hard Iron;
Maximum Operating Pressure 95 psi (655 kPa).*
- Impeller:** G-R Hard Iron.
- Suction Head:** Gray Iron 30.
- Seal Plate:** G-R Hard Iron.
- Motor Housing:** Aluminum Alloy 356-T6.
- Wear Ring:** Copper Alloy 83600.
- Motor Shaft:** Stainless Steel 17-4PH.
- Bearings:** Upper - Two Synthetic Seals, Single Row Ball Bearing.
Lower - Two Shields, Double Row Ball Bearing.
- Discharge Flange:** Gray Iron 30.
- Gaskets:** Cork with Nitrile Binder (NC710).
- O-Rings:** Buna-N.
- Wetted Hardware:** Standard Plated Steel and Stainless Steel.
- Strainer:** Urethane Coated Steel; 48% Open Area,
0.50" (12.7 mm) Diameter Openings.
- Hoisting Bail:** Urethane Coated Steel.

Standard Equipment

NEMA Type 3R Rainproof Control Box. *(See Section 130, Page 90.)*
Provides On-Off, Circuit Breaker and Motor Overload Protection.

Staging Adapter.

Optional Equipment

- Liquid Level Control:** *(See Sec. 130, Page 150.)*
 - a. Turtle Type Pressure Activated Level Switch.
 - b. Float Activated Level Switch.

MOTOR/CABLE SPECIFICATIONS

- Motor:** Air Filled Enclosure with Thermal Overload Protection; 30.0 H.P.; 3450 R.P.M.; Three Phase: 460/575 Volt, 60 Hz, 38.5/30.8 Full Load AMPS, 27.8 kW (Max.)
- Power Cable:** 9 Wire; Type SPC; (3) 8 AWG. Power Conductors, (1) 6 AWG. Ground Conductor, (4) 14 AWG. Control Conductors and (1) 8 AWG. Ground Check. Nominal Length 50 Feet (15 m). Standard. *(Specify Alternate Length at Time of Order.)*
- Recommended Generator Size:** 60 kW Across-the-Line Start. 40 kW for Reduced Voltage Starting.

* Consult Factory for Applications Exceeding Maximum Pressure and/or Temperature Indicated.



WARNING!

Do not use in explosive atmosphere or for pumping volatile flammable liquids.

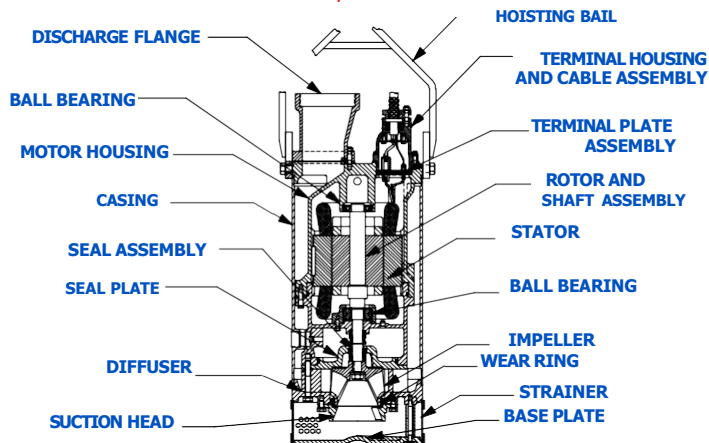
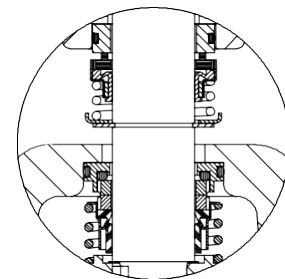

SEAL DETAIL

Tandem, Oil Lubricated.

Upper Seal: Type 21, Mechanical. Carbon Rotating Face. Ni-Resist Stationary Face. Fluorocarbon Elastomers (DuPont Viton® or Equivalent). Stainless Steel 18-8 Cage and Spring.

Lower Seal: Type 2, Mechanical. Silicon Carbide Rotating Face and Tungsten Titanium Carbide Stationary Face. Stainless Steel 316 Stationary Seat. Fluorocarbon Elastomers (DuPont Viton® or Equivalent). Stainless Steel 18-8 Cage and Spring.

Maximum Temperature of Liquid Pumped, 122 F (50 C).*



GORMAN-RUPP PUMPS

www.grpumps.com

Specifications Subject to Change Without Notice

Printed in U.S.A.

Specification Data

SECTION 130, PAGE 1300

APPROXIMATE
DIMENSIONS and WEIGHTS

NET WEIGHT: 570 LBS. (259 KG.)
SHIPPING WEIGHT: 615 LBS. (279 KG.)
EXPORT CRATE: 10.2 CU. FT. (0,29 CU. M.)

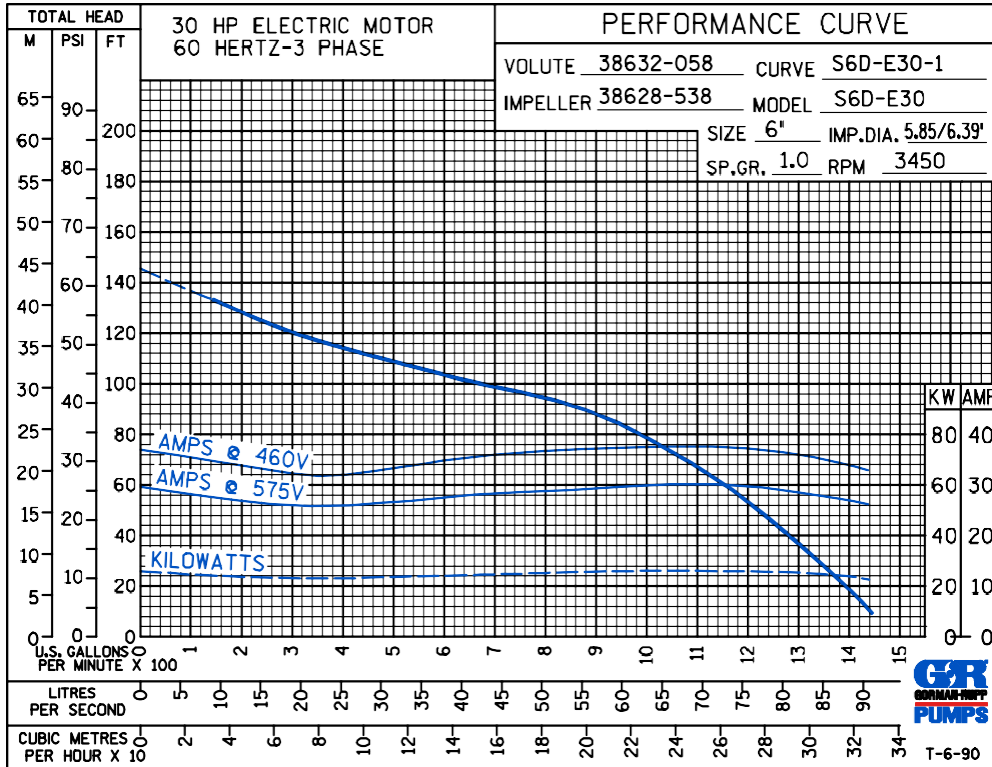
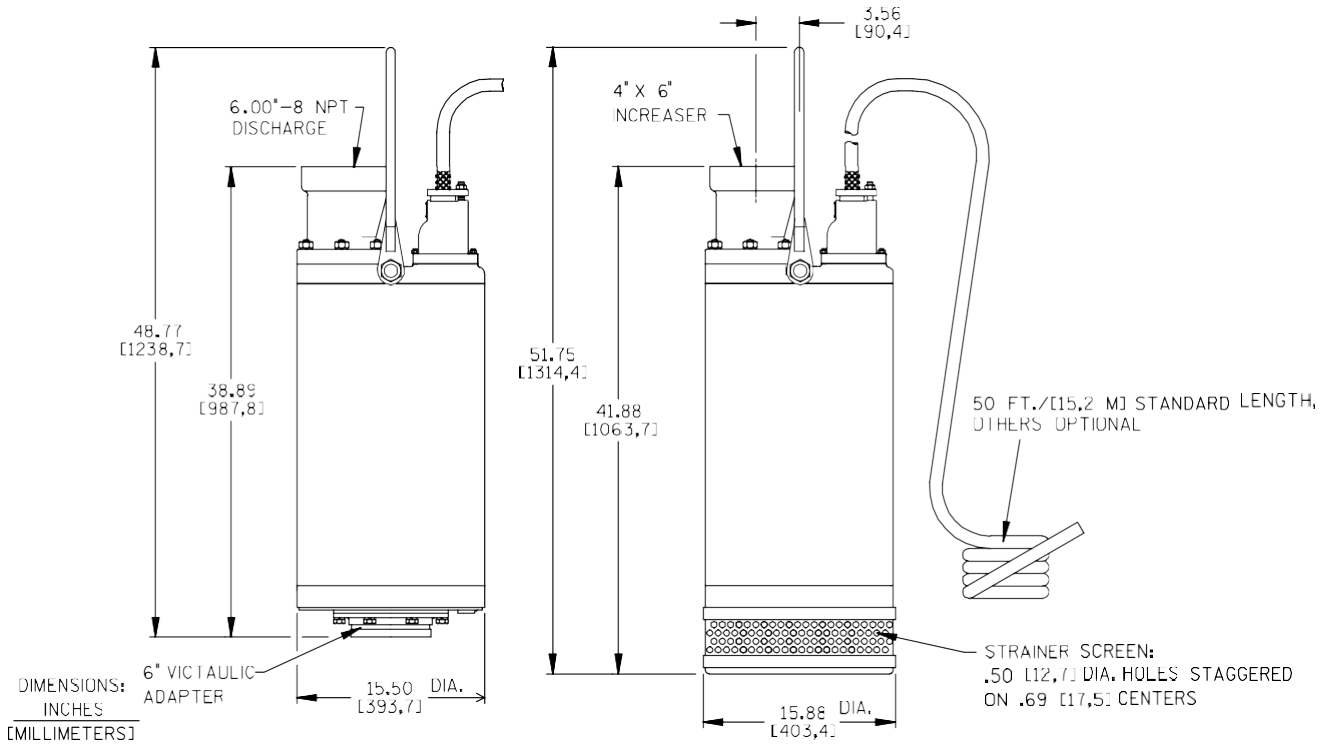

GORMAN-RUPP PUMPS

www.grpumps.com

Specifications Subject to Change Without Notice

Printed in U.S.A.



REQUEST FOR QUOTE# PCRFQC-001681

RFQ# PCRFQC-001681
NstkSvc

Q&A Deadline: 7/26/2024 5:00 PM
Closing Date and Time: 7/31/2024 5:00 PM

VENDOR INFO:

VENDOR#:
NAME:
CONTACT:
ADDRESS:
EMAIL:
PHONE:
FAX:

REPLY TO:
Stephanie Waits
9933 E 16th St.
Tulsa, OK 74128
USA

PHONE: (918) 960-2221
FAX: 0 -
EMAIL: Stephanie.Waits@grda.com

NOTES:

LINE ITEM NUMBER	DESCRIPTION	COMMODITY CODE	QUANTITY	UNIT	UNIT PRICE	LINE COST	LEAD TIME
40151500	Electric Motor Driven Submersible Pump Model S6D1-E30 Size 6" See attached specification data sheet All vendors should meet or exceed these specifications and provide a manufacturer Specification Data sheet with their bid.	40151500	3.00	Ea			

Site: NstkSvc Warehouse: NstkSvc

NOTE: All prices must be quoted FOB: Destination. All freight charges to delivery point must be included in the unit price quoted for each line item. All packaging, handling, delivery and any other surcharges must also be included in the price quoted for each line item.

PAYMENT TERMS: _____

QUOTE EXPIRATION DATE: _____

QUOTATION NUMBER: _____

QUOTED BY (please print): _____

COMPANY NAME: _____

SIGNATURE: _____

DATE OF QUOTE: _____

SHIP TO:
Energy Control Center/ Kerr Dam
4221 E. 545 Road
Locust Grove, OK 74352
USA

THIS IS NOT AN ORDER. We would be pleased to receive your quotation for furnishing the above. This form must be completed in full (including signature) and returned by the due date indicated. You may attach additional pages if necessary. If attached, the Non-Collusion form must be completed and returned with your quotation. All articles purchased hereunder shall be in accordance with the Bidding Procedures and General Terms & Conditions contained on the attached sheets.

A Non-Collusion Certificate shall be included with any competitive bid or contract submitted to the Authority for goods or services exceeding \$5,000.00 for this Request for Proposal or Request for Quote.

A. For purposes of competitive bid or contract, I certify:

1. I am the duly authorized agent of _____, (Company Name),
the bidder submitting the competitive bid which is attached to this statement, for the purpose of certifying the facts pertaining to the existence of collusion among bidders and between bidders and state officials or employees, as well as facts pertaining to the giving or offering of things of value to government personnel in return for special consideration in the letting of any contract pursuant to said bid;
2. I am fully aware of the facts and circumstances surrounding the making of the bid to which this statement is attached and have been personally and directly involved in the proceedings leading to the submission of such bid; and
3. Neither the bidder, nor contractor, nor anyone subject to the bidder's or contractor's direction or control, has been a party:
 - a. to any collusion among bidders in restraint of freedom of competition by agreement to bid at a fixed price or to refrain from bidding,
 - b. to any collusion with any state official or employee as to quantity, quality or price in the prospective contract, or as to any other terms of such prospective contract, nor
 - c. in any discussions between bidders and any state official concerning exchange of money or other thing of value for special consideration in the letting of a contract, nor, whether competitively bid or not, has paid, given or donated or agreed to pay, give or donate to any officer or employee of the State of Oklahoma any money or other thing of value, either directly or indirectly, in procuring this contract herein.

B. The contractor further certifies that no person who has been involved in any manner in the development of said contract while employed by the State of Oklahoma shall be employed to fulfill any of the services provided for under said contract.

C. If any contract pursuant to this bid is for professional services as defined in 74 O.S. § 85.2.25, and if the final product is a written proposal, report or study, the contractor further certifies that (s)he has not previously provided the state agency or any other state agency with a final product that is a substantial duplication of the final product of the proposed contract.

Authorized Signature

Certified this Date

Printed Name

Title

Telephone Number

Fax Number

E-Mail

GENERAL TERMS AND CONDITIONS



Any contract or purchase order (PO) issued by the Grand River Dam Authority (GRDA) is expressly conditioned upon Seller's assent to these terms and conditions. Any order issued or filled by Seller shall be deemed to constitute Seller's assent to these terms and conditions. GRDA must give its express written consent to all additional terms submitted by Seller and all modified terms proposed by Seller.

1. Email, mail, or deliver all invoices or correspondence pertaining to the payment of this PO/ Contract to: Accounts Payable Department at accounts.payable@grda.com or Grand River Dam Authority, P.O. Box 669 Chouteau, Oklahoma 74337. Seller shall provide an invoice which is in accordance with the terms of the appropriate PO/Contract and applicable state or federal statutes, including but not limited to such documentation as may be required to demonstrate that the task has been achieved. Seller shall submit invoices accompanied by complete supporting documentation for shipping costs. If shipment is not made by routing instructions as specified on the face of this PO/Contract, GRDA has the right to deduct any excess transportation charges resulting therefrom. Copy of original freight bill must be supplied for payment if freight charge is in excess of \$500.00. Time, in connection with any discount offered, will be computed from date of delivery of items or services, or from date the correct invoice is received at GRDA Headquarters in Chouteau, Oklahoma, whichever period of time is the later date. No Oklahoma State Sales or Use Tax shall be paid by GRDA.
2. GRDA has the right to inspect articles, materials, and supplies before and during manufacture and upon arrival at destination and to return for full credit and/or refund, at Seller's sole risk and expense, including all transportation and storage charges, all items found defective or furnished contrary to instructions and/or specifications contained herein.
3. In case of default by Seller, GRDA may procure the items or services from other sources. Seller agrees to be responsible for any excess cost occasioned thereby; provided, that if necessity requires the use of items not conforming to specifications, they may be accepted, and payment made at a proper reduction in price. Notwithstanding anything herein to the contrary, GRDA reserves the right to terminate this PO/Contract for its convenience. In the event of such termination, GRDA shall pay and Seller shall accept the reasonable value of all work performed and items delivered by Seller up through the effective date of such termination.
4. Seller represents and warrants that all items and/or services furnished under this PO/Contract will (a) conform to the specifications, drawings, samples or other description furnished by GRDA, or any revisions thereof;(b) be merchantable of good material and free from defect in workmanship, material, and design; (c) be fit and sufficient for the purpose intended; (d) satisfy any performance guarantee requirements as specified herein by GRDA; (e) be free and clear of all liens, security interests or other encumbrances; (f) not infringe or misappropriate any third party's patent, copyright, trademark, or intellectual property rights.; (g) Seller shall implement all necessary physical and cyber security measures to fully insure that GRDA's data is only accessible by Seller's authorized personnel, and that only Seller's authorized personnel may send invoices and seek payment from GRDA for this purchase; and (h) all invoices arising from or related to this purchase that are sent from Seller's domain have been authorized by Seller. In the event the items and/or services purchased hereunder do not meet the warranty specified herein above, Seller shall promptly repair or replace any defective item at its expense, or re-perform any necessary services, and shall hold GRDA harmless from all costs and expenses incurred due to said defective item or performance of services, including the cost for removing any part or product to be repaired or replaced, as well as transportation and installation charges in connection with the repair, replacement or servicing of any parts or equipment. Seller further represents and warrants that the manufacturer's warranty and guarantee of the items purchased hereunder extended to Seller shall extend to GRDA. These warranties are cumulative and in addition to all other warranties provided by law.
5. Seller shall indemnify, defend, and hold harmless GRDA and its officers, directors, employees, and agents, from and against all liabilities, judgments, damages, claims, suits, injuries, losses, and expenses, including attorney fees, arising out of or resulting in any way from: (a) any act or omission of Seller or Seller's officers, directors, employees, subcontractors, and agents; (b) all liens or claims in any way related to the items or services furnished by Seller; (c) all patent, trademark or copyright infringement or alleged infringement, except where strict compliance with the specifications prescribed by GRDA is the sole basis of the infringement or alleged infringement; (d) defects in the items or services furnished by Seller; (e) any unauthorized access to Seller's electronic system(s) by either third parties or unauthorized Seller personnel; or (f) Seller's failure to comply with any of these General Terms and Conditions. This indemnity obligation shall be in addition to the warranty obligations of Seller.
6. When doing work or providing services on GRDA property seller shall, before any items are shipped and/or any services are commenced, provide GRDA with certificates evidencing that the following minimum insurance will remain in force until Seller's obligations are completed: (a) Workers' Compensation Insurance, including Employer's Liability Insurance, in accordance with the laws of the state in which Seller may be required to pay compensation; (b) Commercial General Liability Insurance with limits no less than \$1,000, 000 for each occurrence and \$2,000,000 in the aggregate, unless otherwise specified within the solicitation documents; and (c) if Seller will use or provide for the use of motor vehicles in furnishing items and/or services under this PO/Contract, automobile insurance covering all liabilities for personal injury and property damage arising from the use of such vehicles, with a limit of no less than \$1,000,000.
7. Seller shall not assign or subcontract any of its rights or obligations under this PO/Contract without GRDA's prior written consent. No assignment shall relieve Seller of its obligations hereunder.
8. Service Contracts: By submitting a bid for services, the Bidder certifies that it, and any proposed Subcontractors, are in compliance with 25 O.S. § 1313 and participate in the Status Verification System. The Supplier/Contractor/Consultant/Construction Manager/et c. certifies that it and all proposed Subcontractors, whether known or unknown at the time a contract is executed or awarded, are in compliance with 25 O.S. § 1313 and participate in the Status Verification System. The Status Verification System is defined in 25 O.S. § 1312 and includes, but is not limited to, the free Employment Verification Program (E-Verify) available at www.dhs.gov/E-Verify. This shall remain in effect through the entire term, including all renewal periods, of the Contract. The State may request verification of compliance for any Seller or Subcontractor. Should the State suspect or find the Seller or any of its Subcontractors are not in compliance, the State may pursue any and all remedies allowed by law, including, but not limited to: suspension of work, termination of the Contract for default, and suspension or debarment of the Seller. All costs necessary to verify compliance are the responsibility of the Seller.
9. All Items shipped pursuant to this PO/Contract will conform to all municipal, state and federal laws, ordinances and regulations, and Seller will defend and save harmless GRDA from loss, costs or damage by reason of any actual or alleged violation thereof.

10. GRDA hereby notifies Seller that Seller must comply, and by acceptance of this PO/Contract, Seller represents that it has complied with, and will continue to comply with, all applicable federal, state and local laws, regulations or orders.
11. This PO/Contract shall be interpreted and construed in accordance with the laws of the State of Oklahoma. The state district courts in Tulsa County, Oklahoma, will have exclusive jurisdiction and venue to resolve any dispute arising from or related to this PO/Contract.
12. AUDIT RIGHTS. Seller/Contractor will, at all times during the term of this PO/Contract and for a period of five (5) years after the completion of this PO/Contract, maintain and make available for inspection and audit by GRDA and/or the Oklahoma State Auditor, all books, supporting documents, accounting procedures, practices, and all other items relevant to the PO/Contract.
13. By submitting a bid, bidder certifies that it is not currently engaged in a boycott of goods or services from Israel that constitutes an integral part of business conducted or sought to be conducted with the state.
14. By submitting a bid, the parties to this Agreement certify that no person who has been involved in any manner in the development of this Agreement while employed by the State of Oklahoma will be employed to fulfill any of the services provided for under this Agreement.
15. For any services performed pursuant to the PO/Contract, in addition to complying with the other provisions of these *General Terms and Conditions*, Seller must: (i) supply and remove all necessary tooling, equipment, and materials; (ii) remove and lawfully dispose of all debris, and provide evidence to GRDA of such lawful disposition upon GRDA's request; (iii) comply with all applicable codes, standards, laws, and standards of care applicable to the services provided; (iv) take all necessary precautions, at all times, for the health and safety of Seller personnel (including employees, contractors, and agents) at the site, and be exclusively responsible for any health or safety violations by Seller's employees, contractors, or agents; (v) maintain, at all times, title to and control of any hazardous materials that require special handling or disposal, and take whatever steps and precautions are necessary to safely eliminate any hazardous condition in accordance with applicable law; (vi) obtain, at Seller's sole expense, any necessary intellectual property rights necessary for Seller to complete the services; and (vii) strictly comply with each provision of the *Supplemental Terms of Service* attached hereto as Attachment A, if the provision below indicating that Attachment A is included in these terms has been selected by GRDA.
16. Paragraphs 3, 4, 5, 9, 10, 11, 12, 15, and 17 will survive termination or cancellation of the contract.
17. Supplemental Terms. If any of the following boxes are checked, the associated terms and conditions are incorporated by reference into these *General Terms and Conditions*:

- Supplemental Terms of Service* (Exhibit GTC-1)
- Schedule 2 - GRDA Supply Chain Cyber Security* (Exhibit GTC-2)

TERMS & CONDITIONS EXCEPTION STATEMENT

RFQ 1681

This part of the proposal must be completed even if no exceptions are stated.

EXCEPTIONS (Attach additional pages if required. If no exceptions, state "NONE".)

An "Exception" is (1) Bidder's inability or unwillingness to meet a term, condition, or specification in the manner specified in the Request for Proposal and/or (2) an additional term, condition, or specification proposed by Bidder. Copies of (1) the proposed Contract or GRDA Terms and Conditions and/or (2) Specifications are included in the Request for Proposal. In a document titled "Exception Statement" Bidder must clearly identify all Exceptions to the terms, conditions, and specifications. Bidder must also state with specificity the reasons for taking Exceptions and all modified terms and additional terms it proposes to be included in the final Contract or GRDA Terms and Conditions and Specifications.

One of the GRDA's evaluation criteria will be the number and extent of the Exceptions. Bids containing Exceptions to the Contract, Terms and Conditions, and/or Specifications may be rejected as non-responsive. Other than Exceptions that are stated in the Exception Statement, each Bidder will be deemed to have agreed to comply with all terms, conditions, and specifications of this request for proposal. If Exceptions are not identified in the Bid Proposal, any Exception raised following the notification of the award of the contract could result in the Bid Proposal being rejected from further consideration.

If Exceptions are not identified in the Bid Proposal, any Exception raised following the notification of the award of the contract may not be considered and may result in the Bid Proposal being rejected from further consideration.